

# Product Generation

## Chapter 9

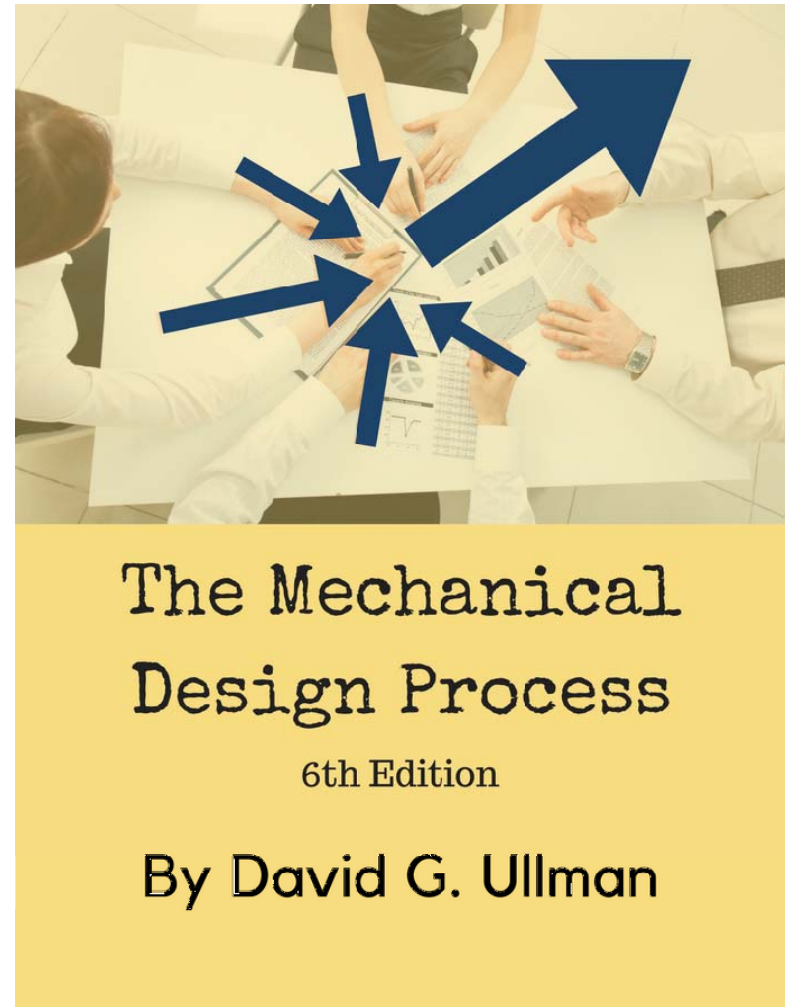
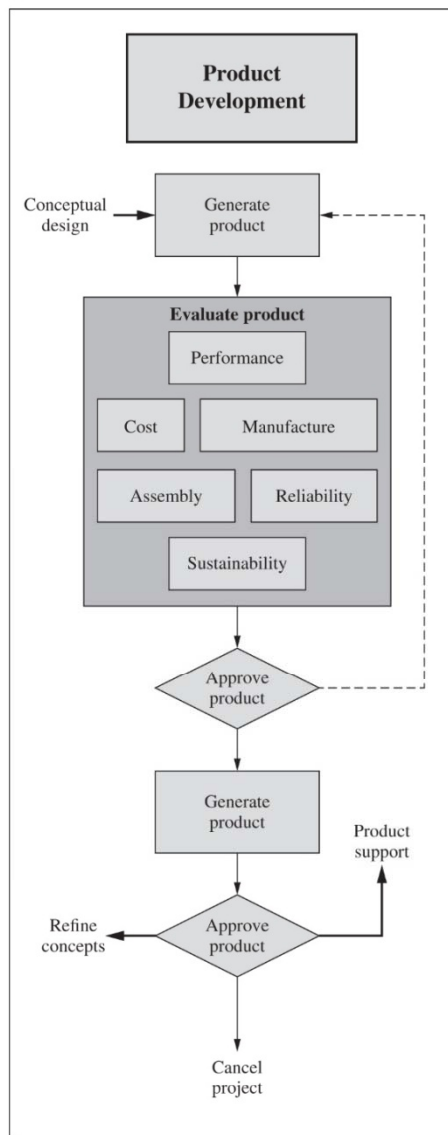
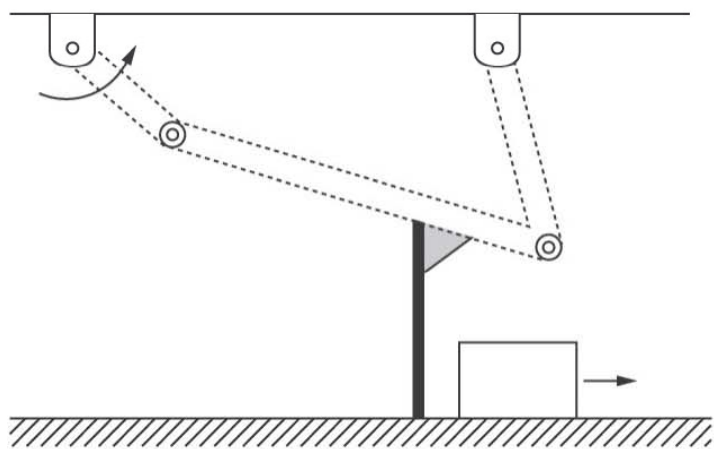

Figure 9.1





(a)



(b)

Figure 9.3

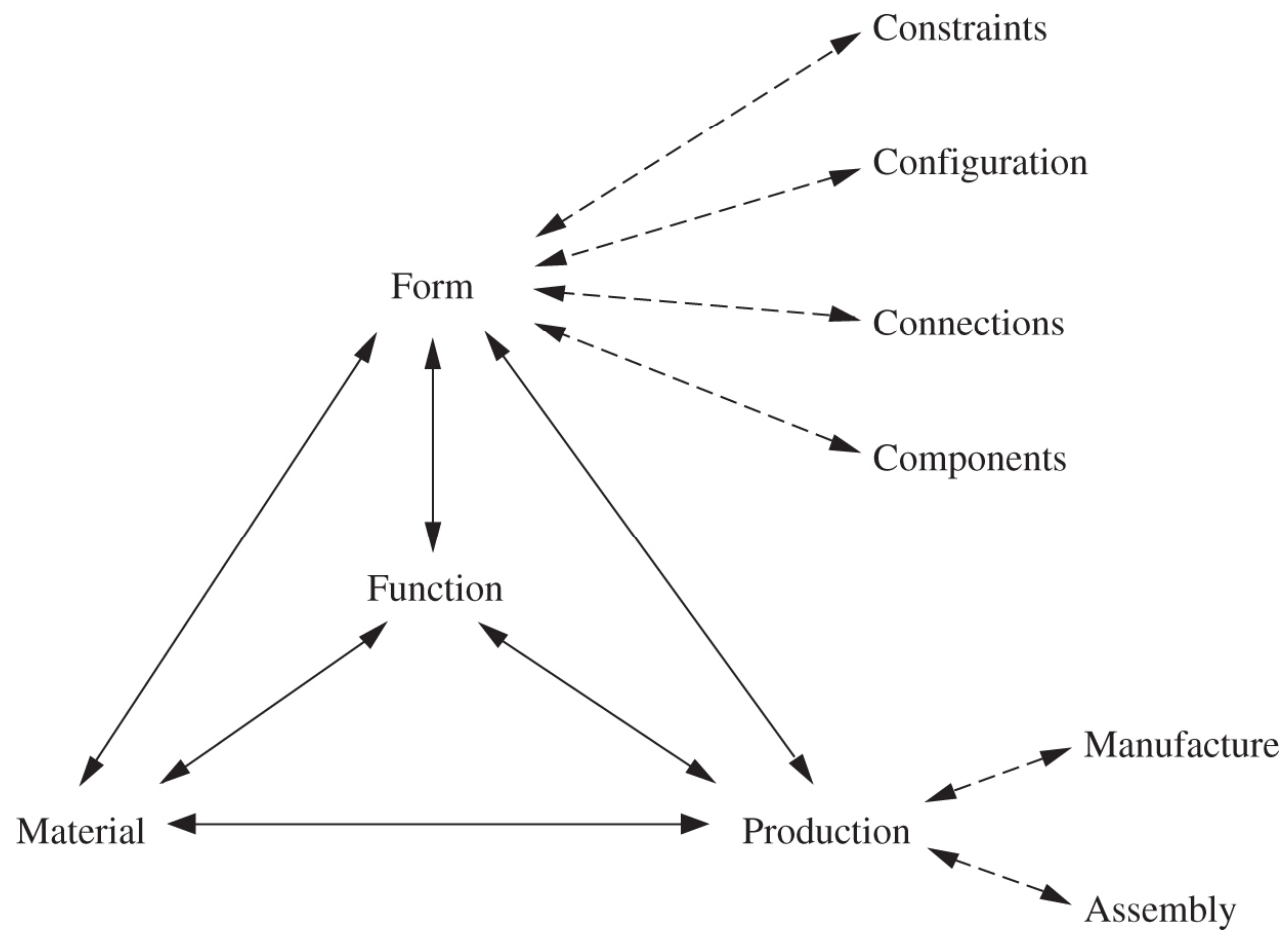
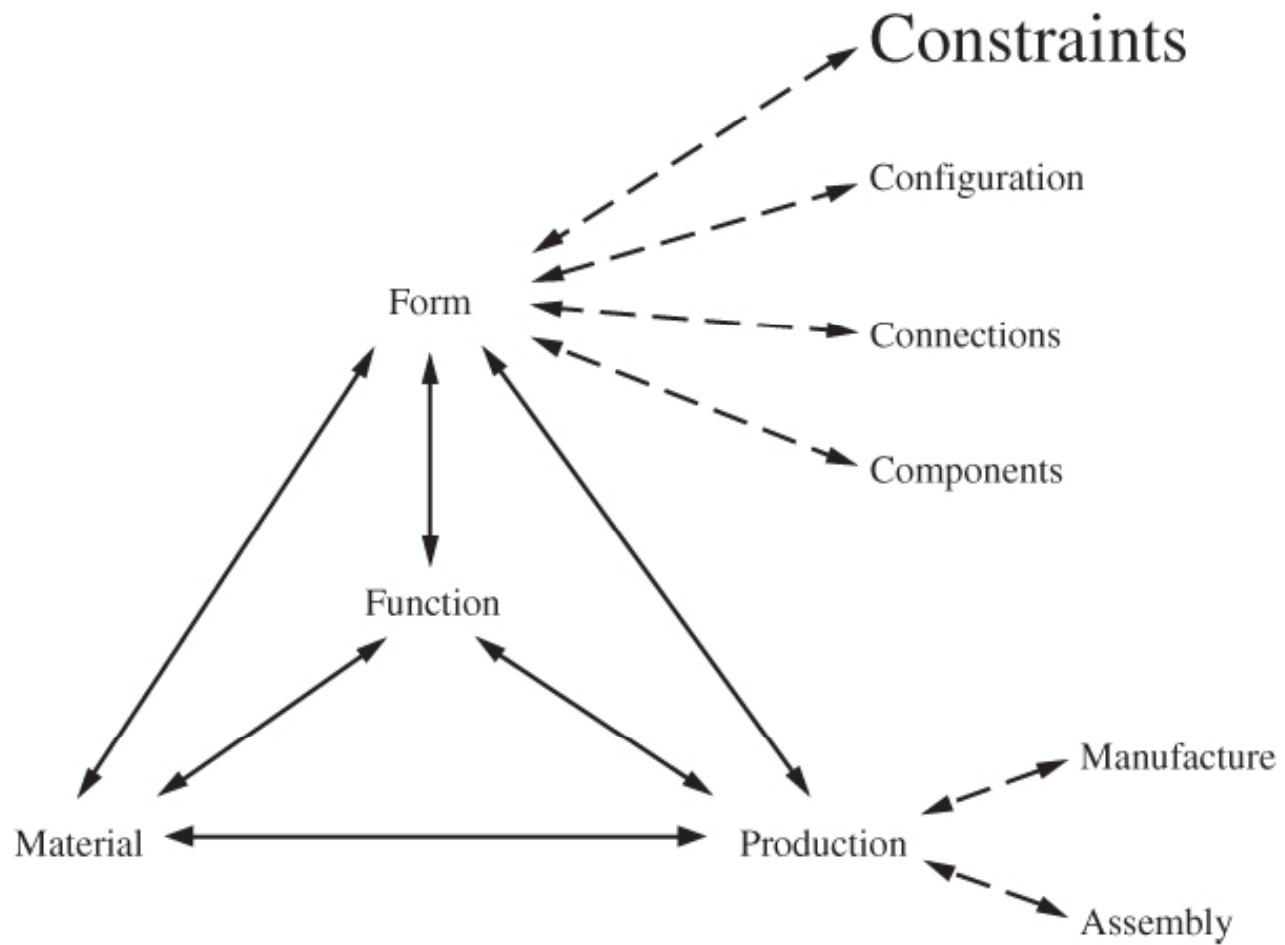

Figure 9.4

Bill of Materials					
Product: Everlast				Date: 03/03/14	
Assembly: Shock Assy					
Item #	Part #	Qty	Name	Material	Source
1	63172-2	1	Outer tube	1018 carbon steel	Coyote Steel
2	94563-1	1	Roller bearing		Bearings Inc.
3	..	..	..	...	..
4	..	..	..	...	..
9	74324-2	3	Shaft	304 stainless steel	Coyote Steel
10	44333-8	1	Link rubber	Urethane	Reed Rubber
Team member: Bob			Prepared by: Jan		
Team member: Jan			Checked by: Bob		
Team member:			Approved by: Dr. Roberts		
Team member:					Page 1/4
<i>The Mechanical Design Process</i>			Designed by Professor David G. Ullman		
Copyright 2014, David Ullman			Form# 23.0		



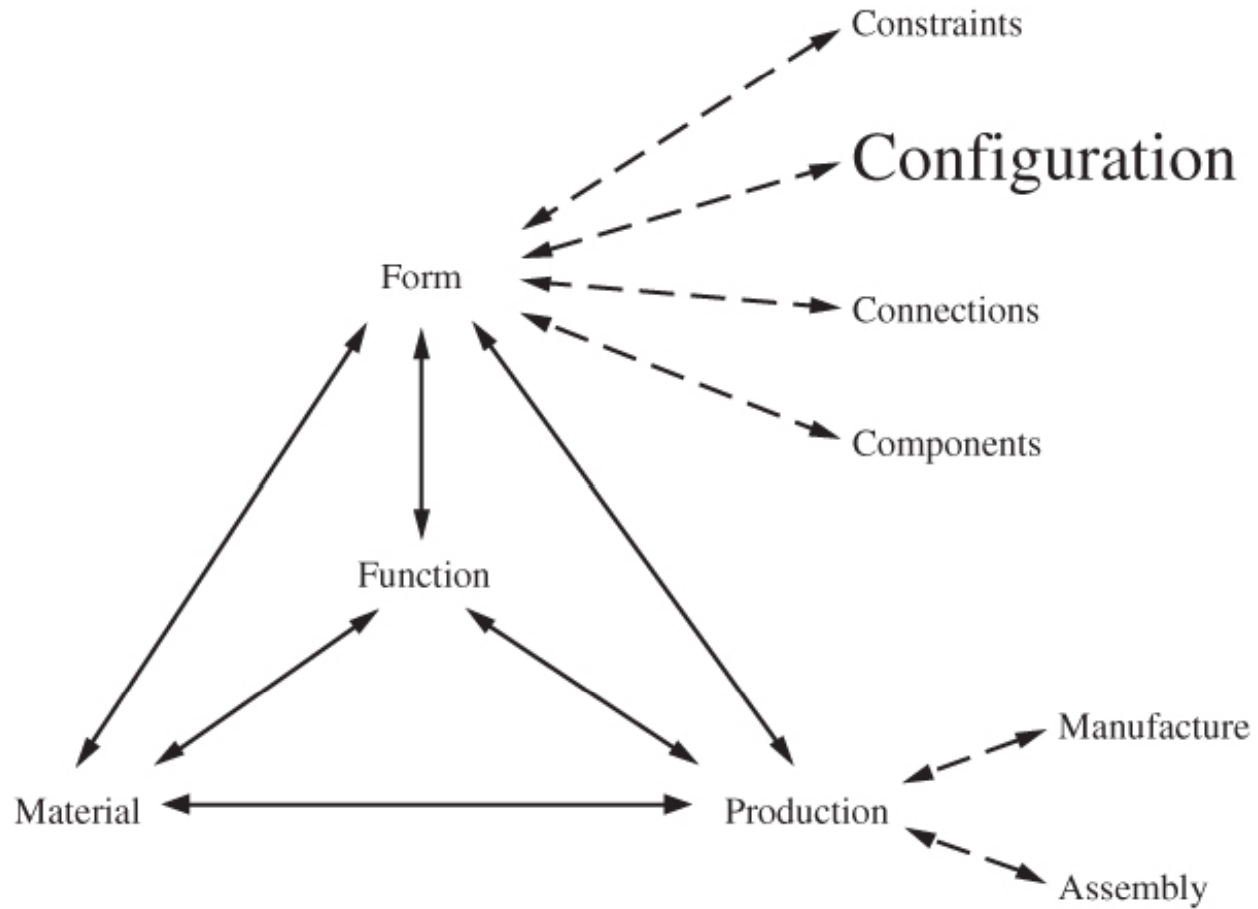
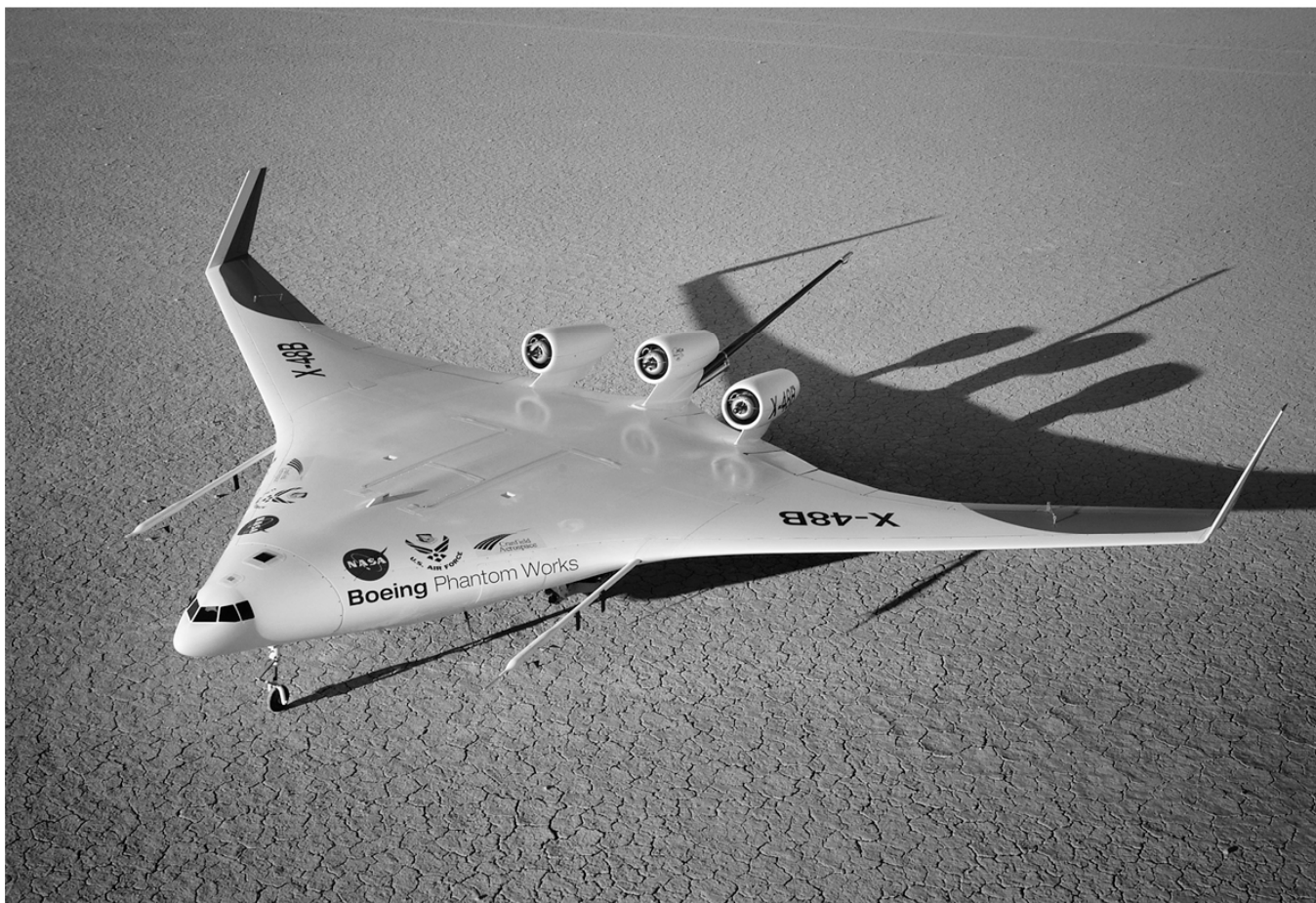

Figure 9.5



NASA



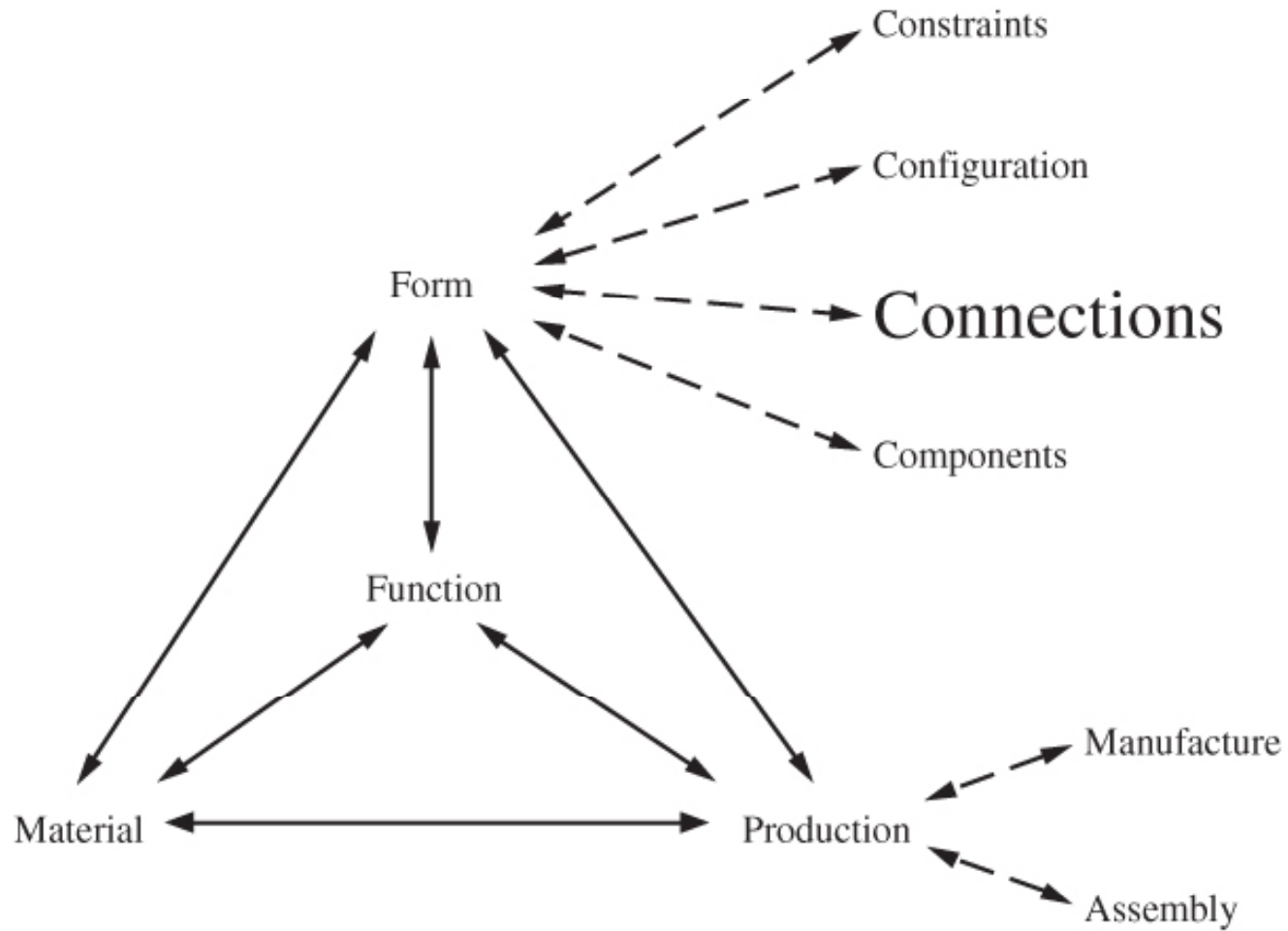

Figure 9.6

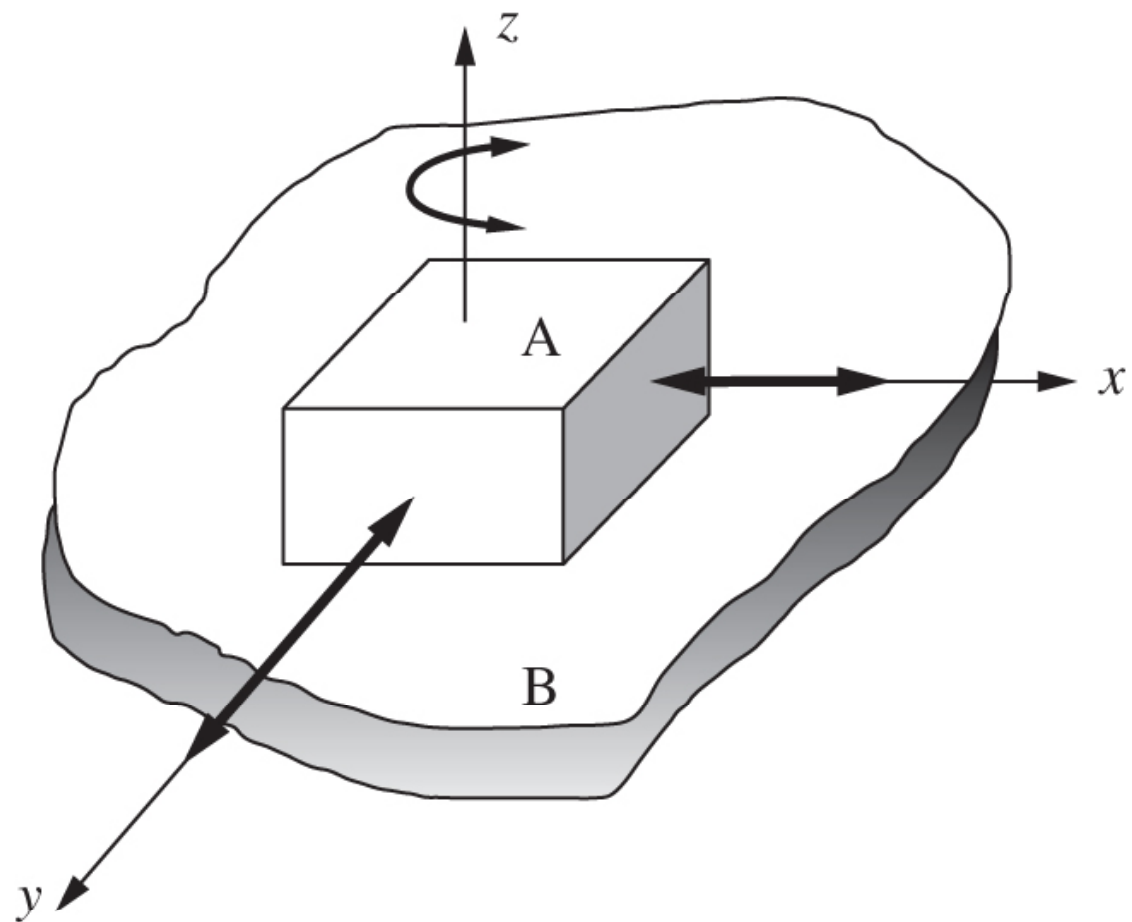

Figure 9.7

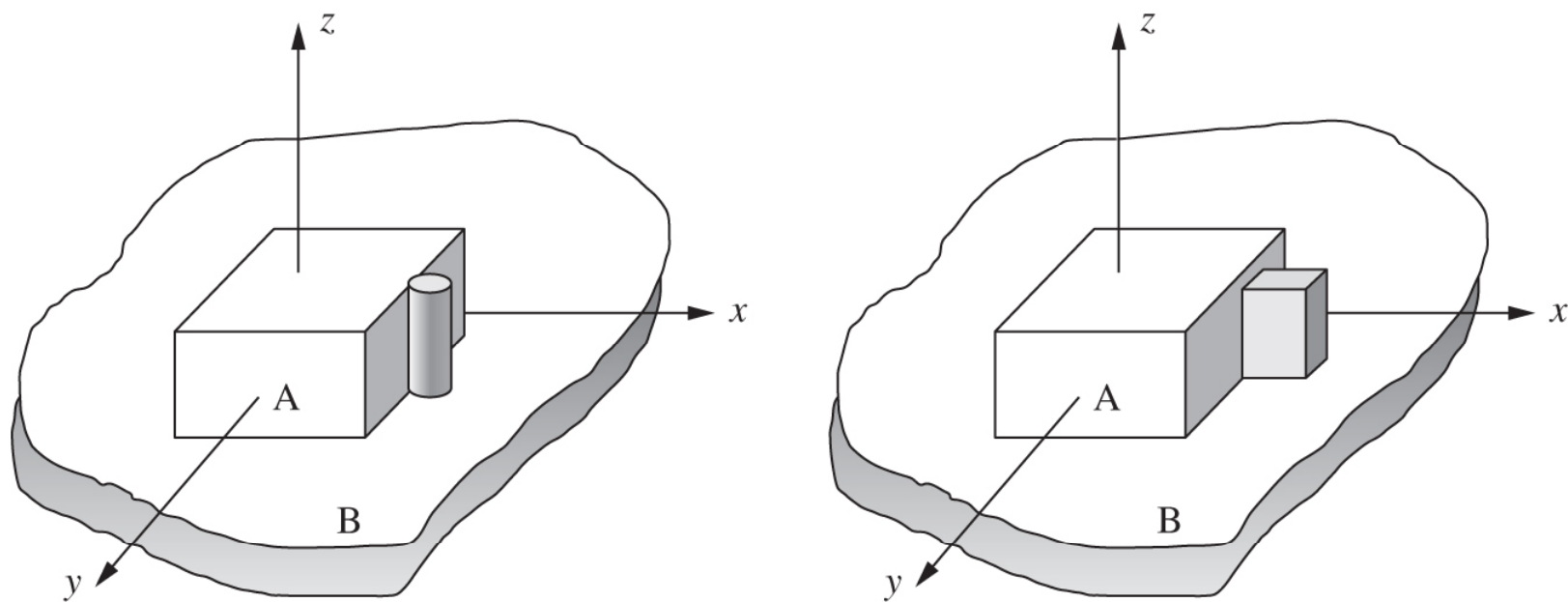

Figure 9.8

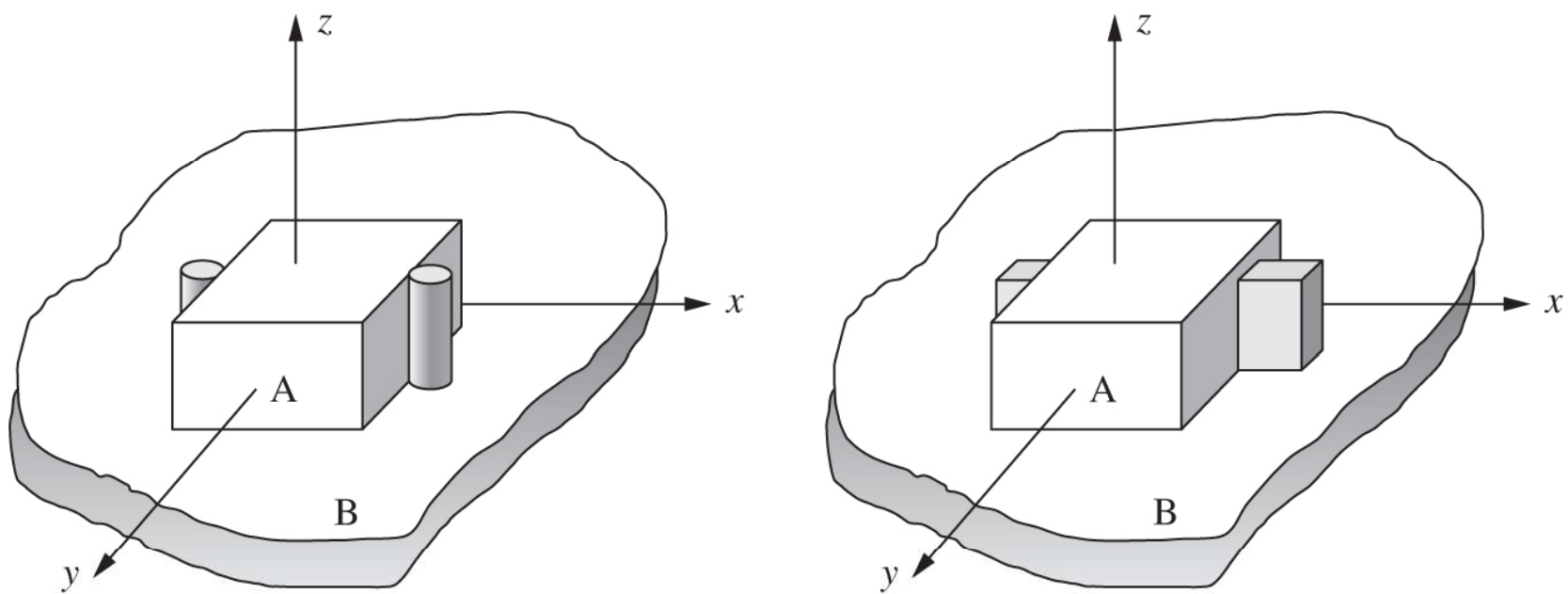

Figure 9.9

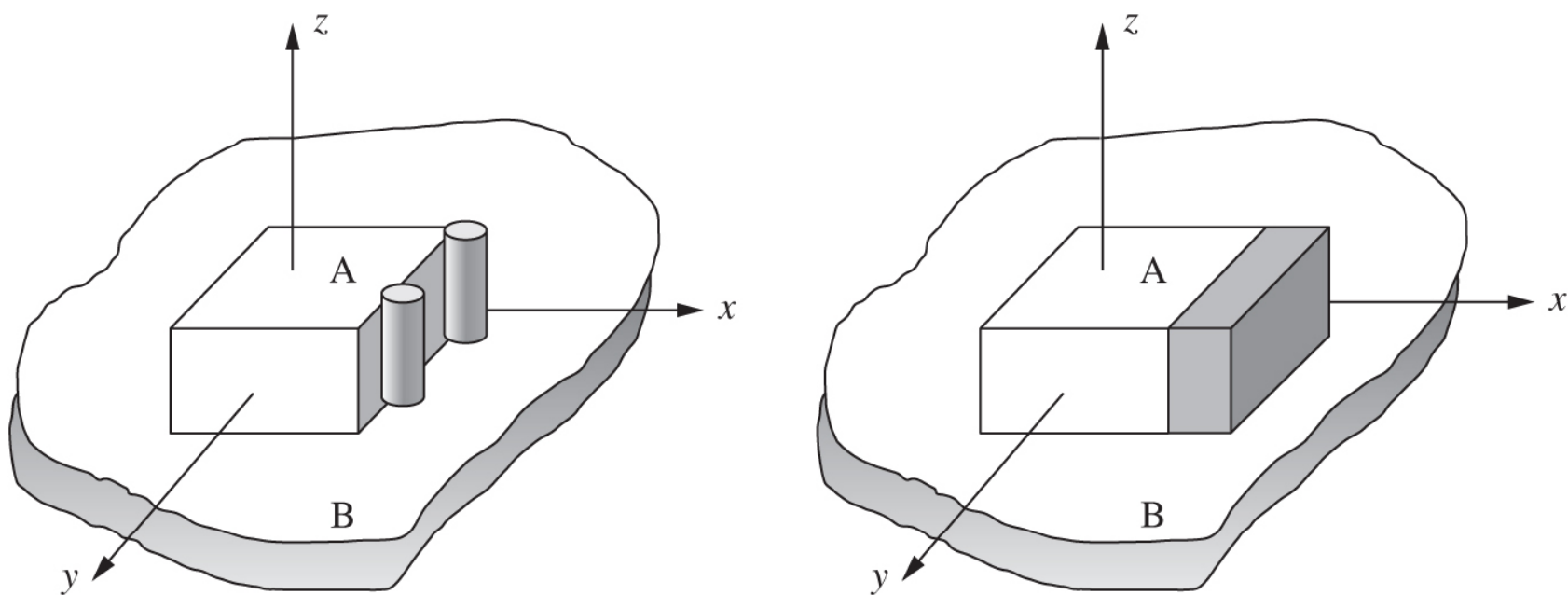

Figure 9.10

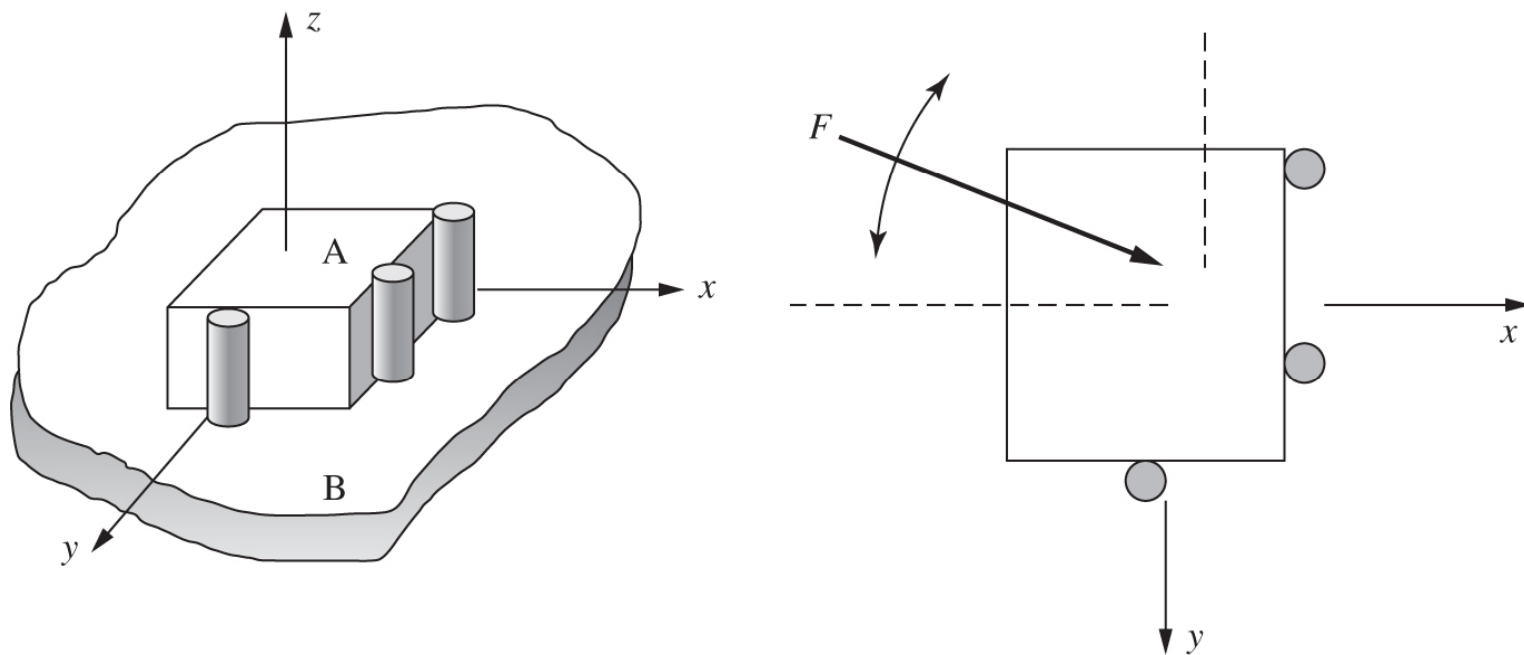
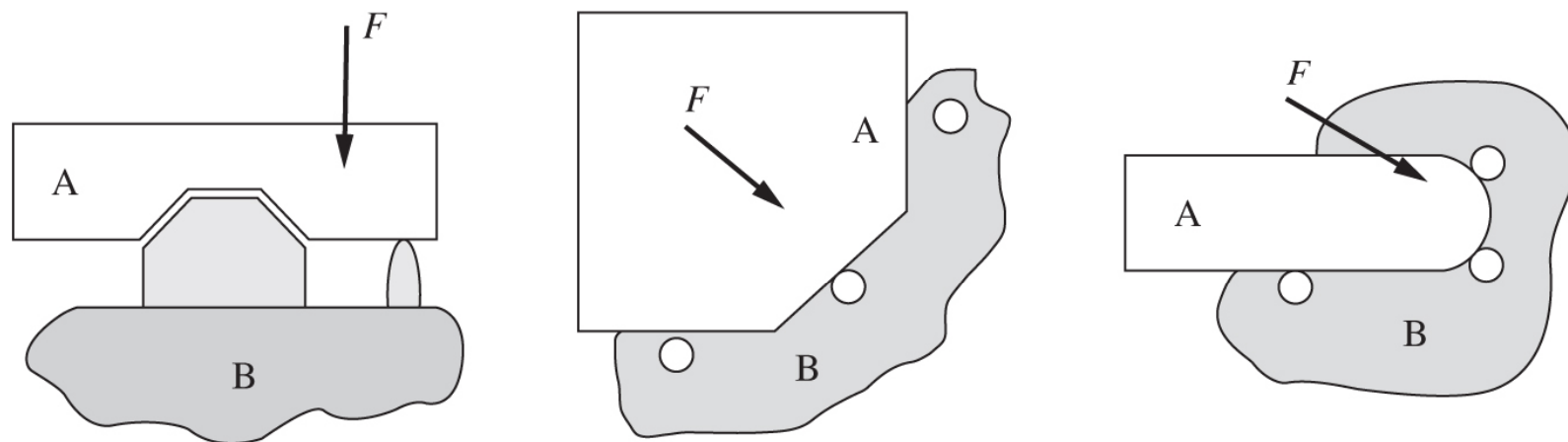

Figure 9.11



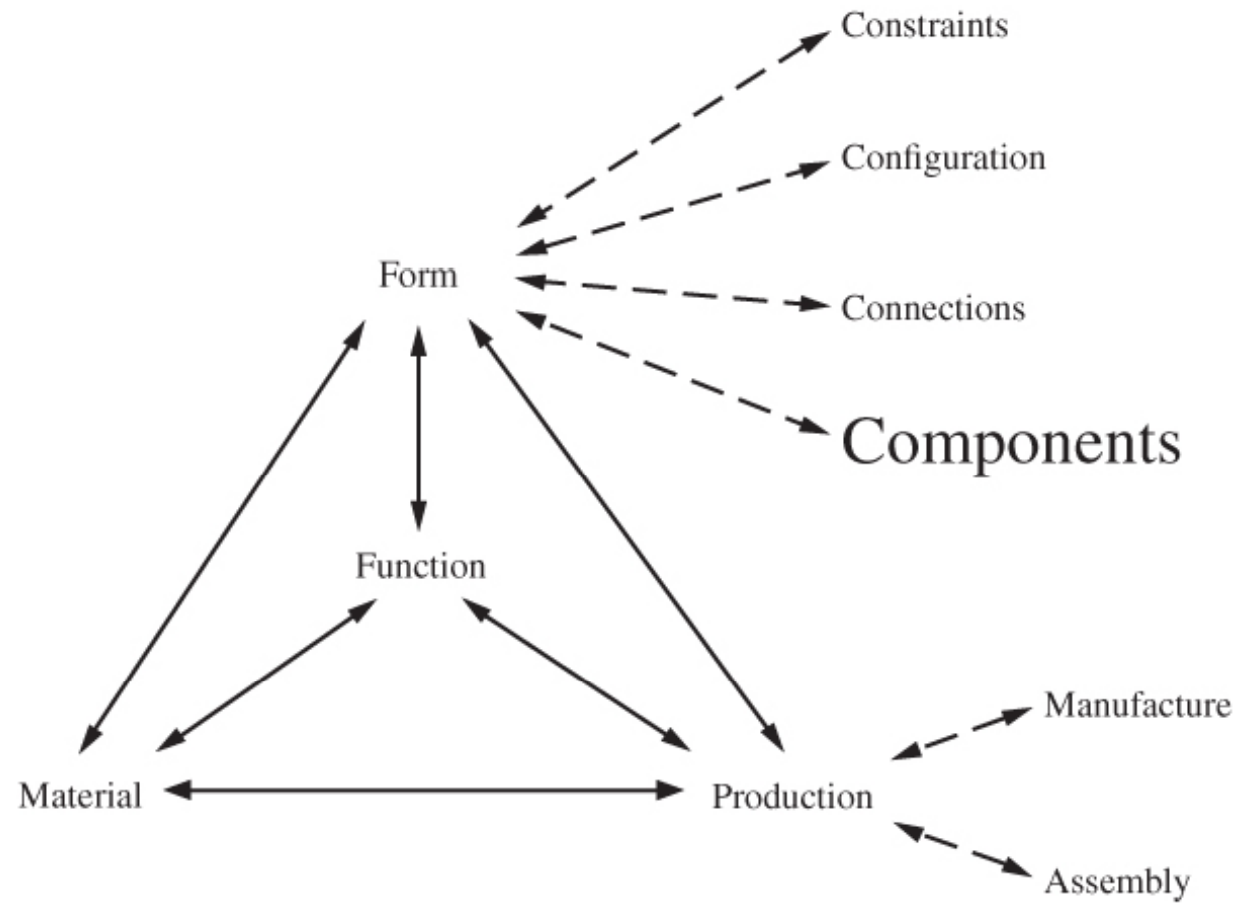



Figure 9.12

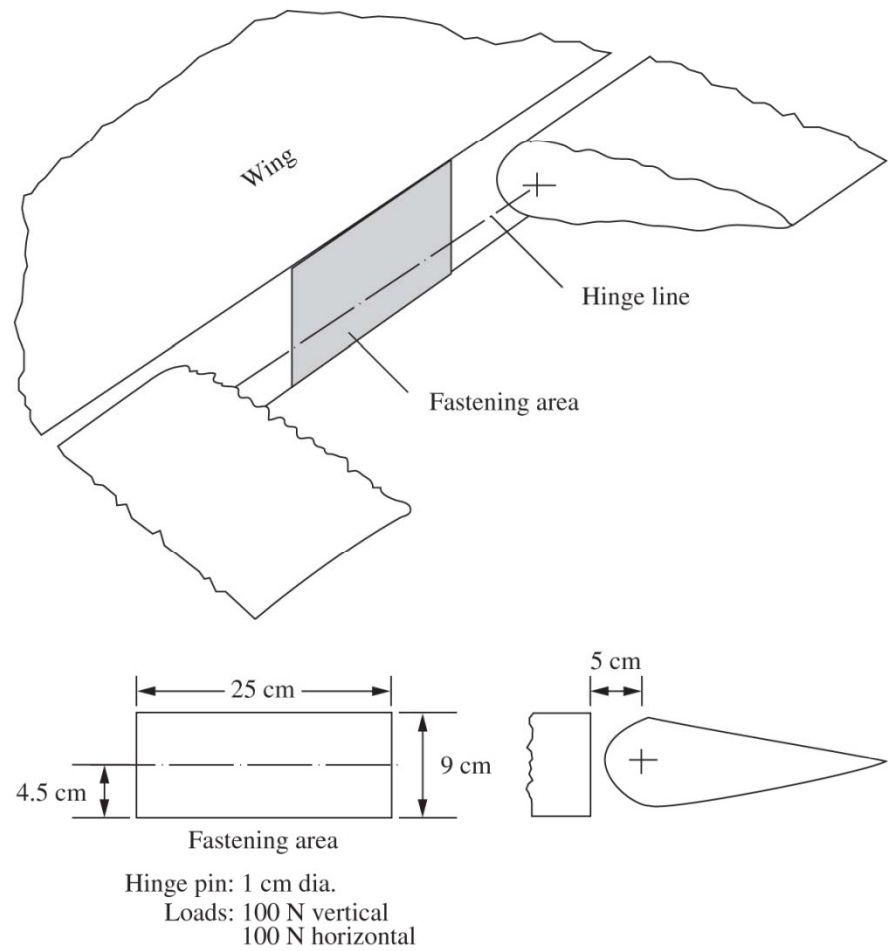
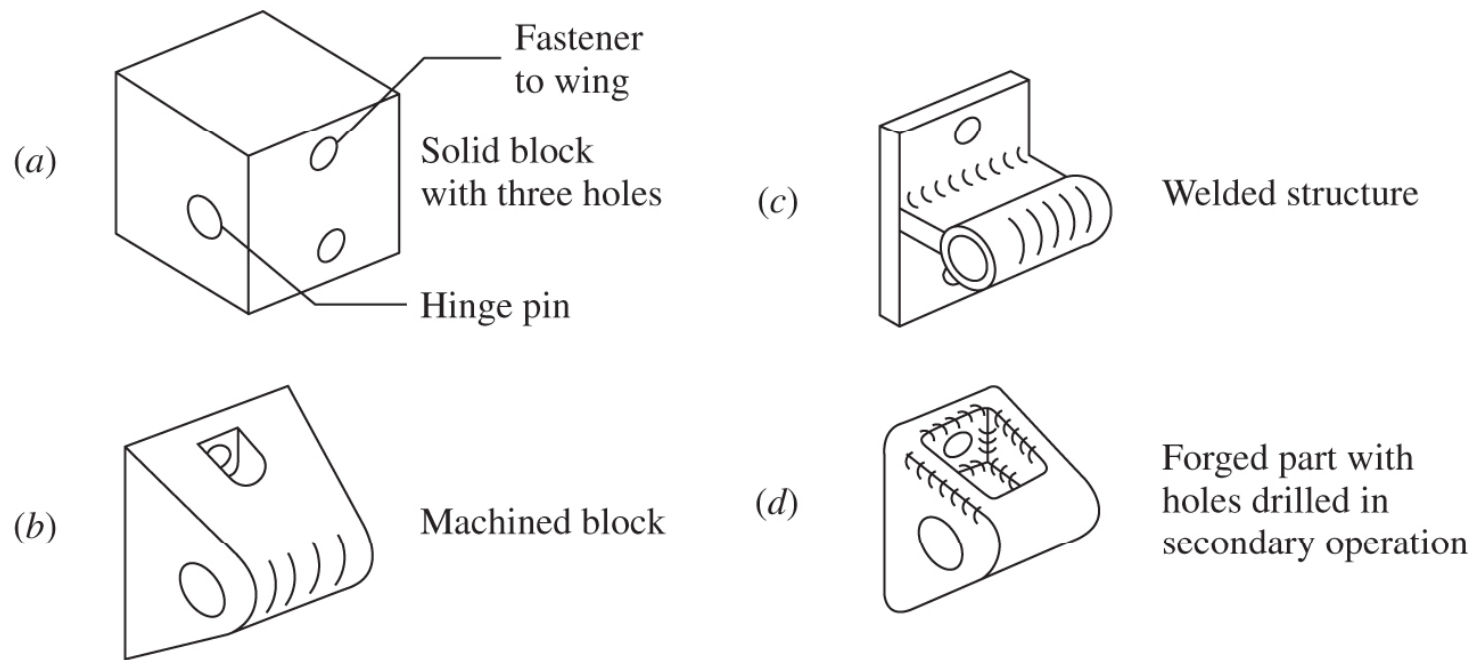

Figure 9.13



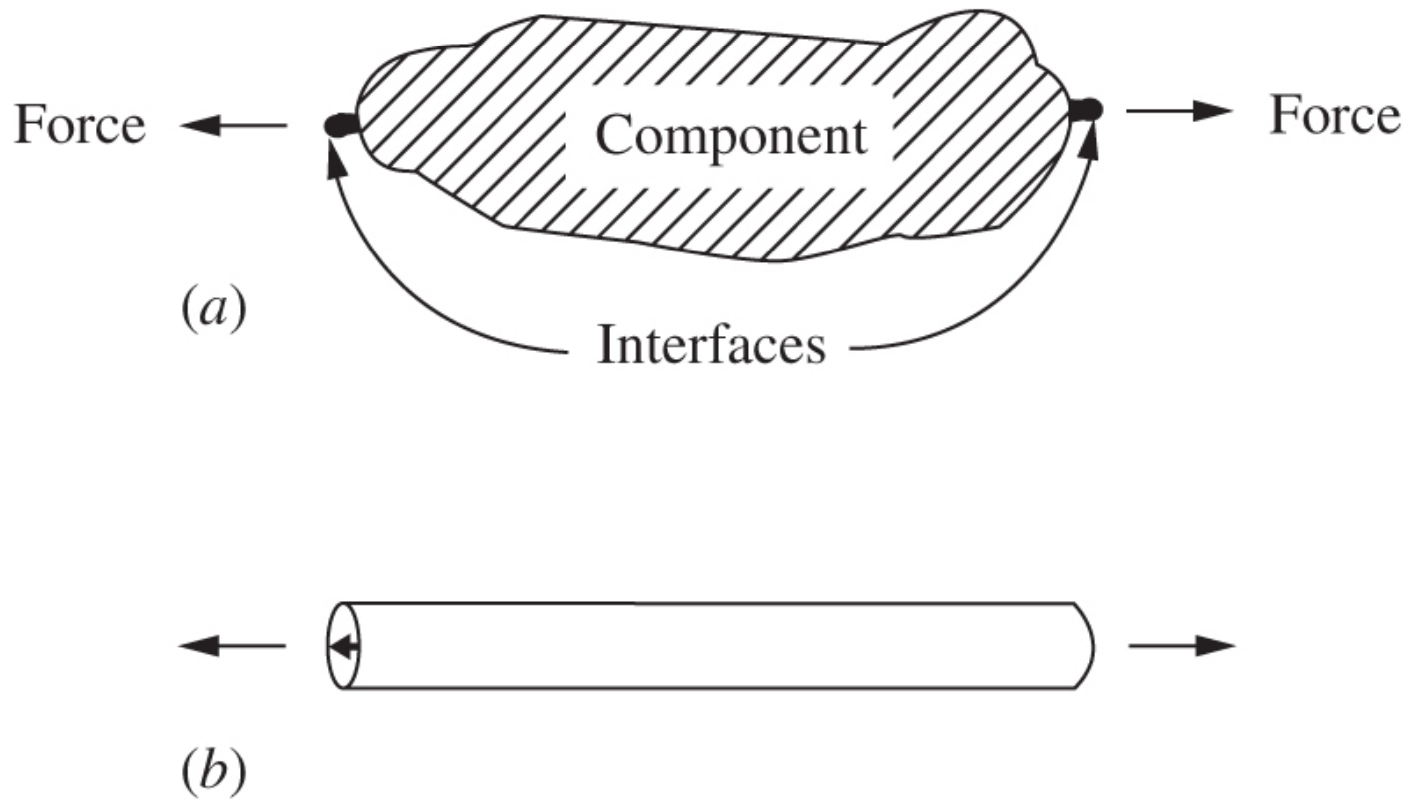

Figure 9.15

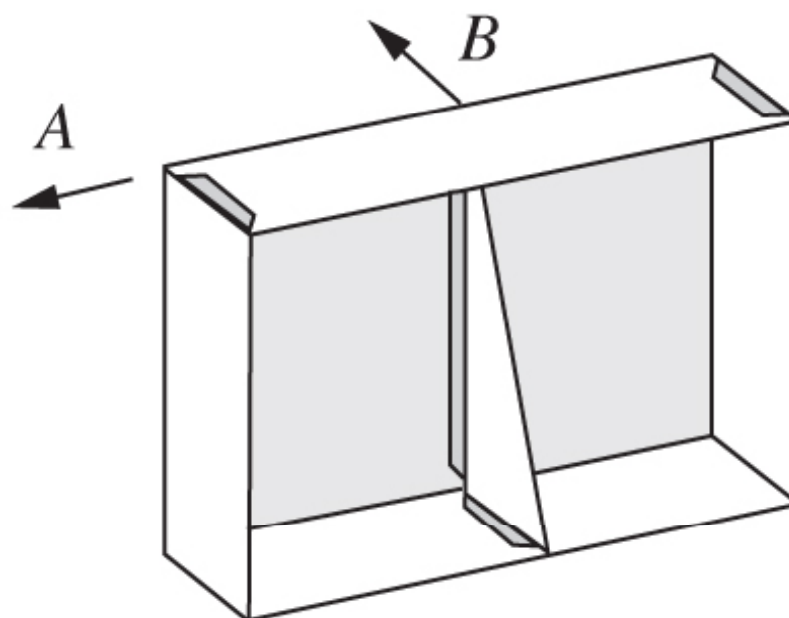

Figure 9.16

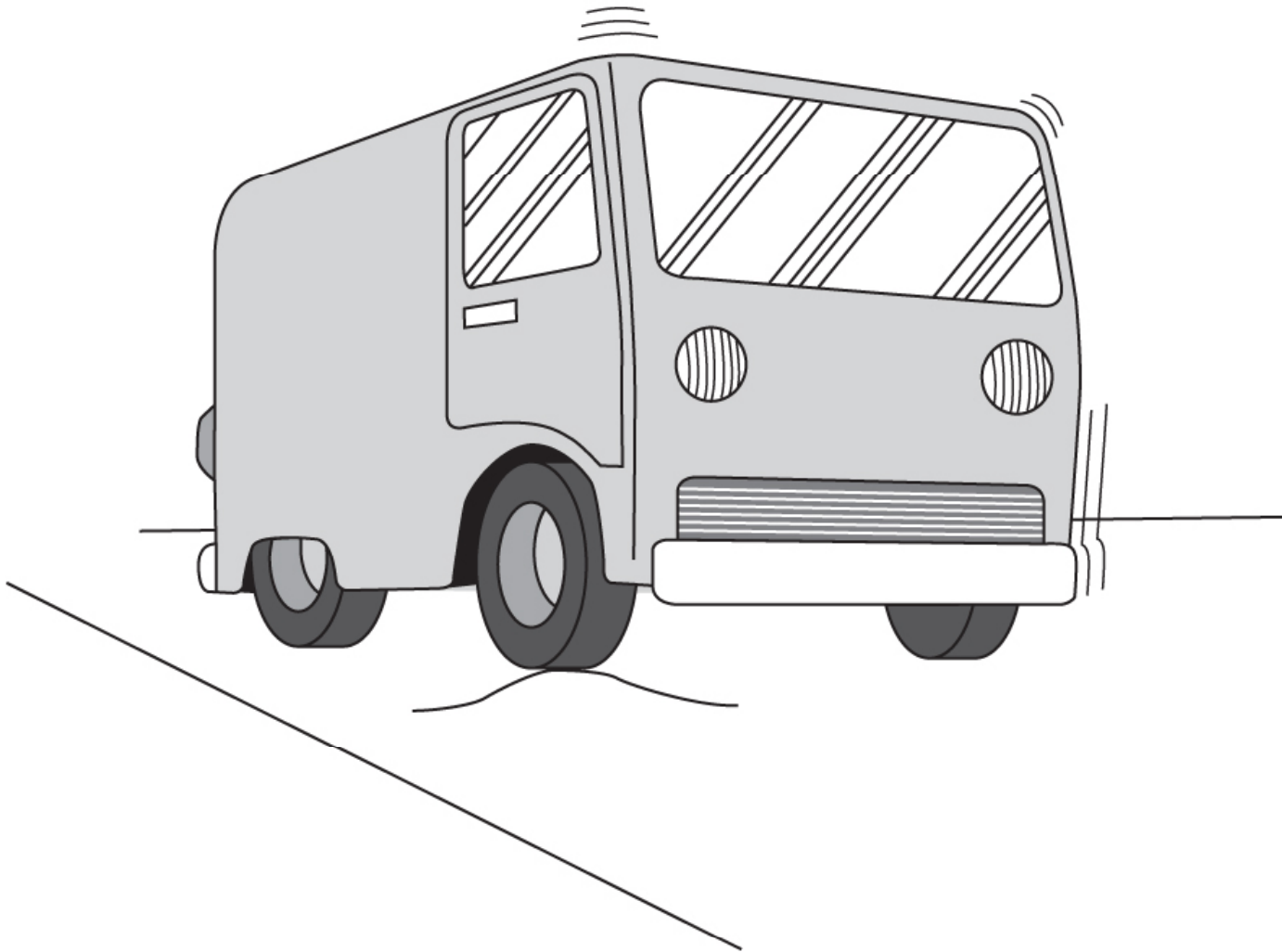
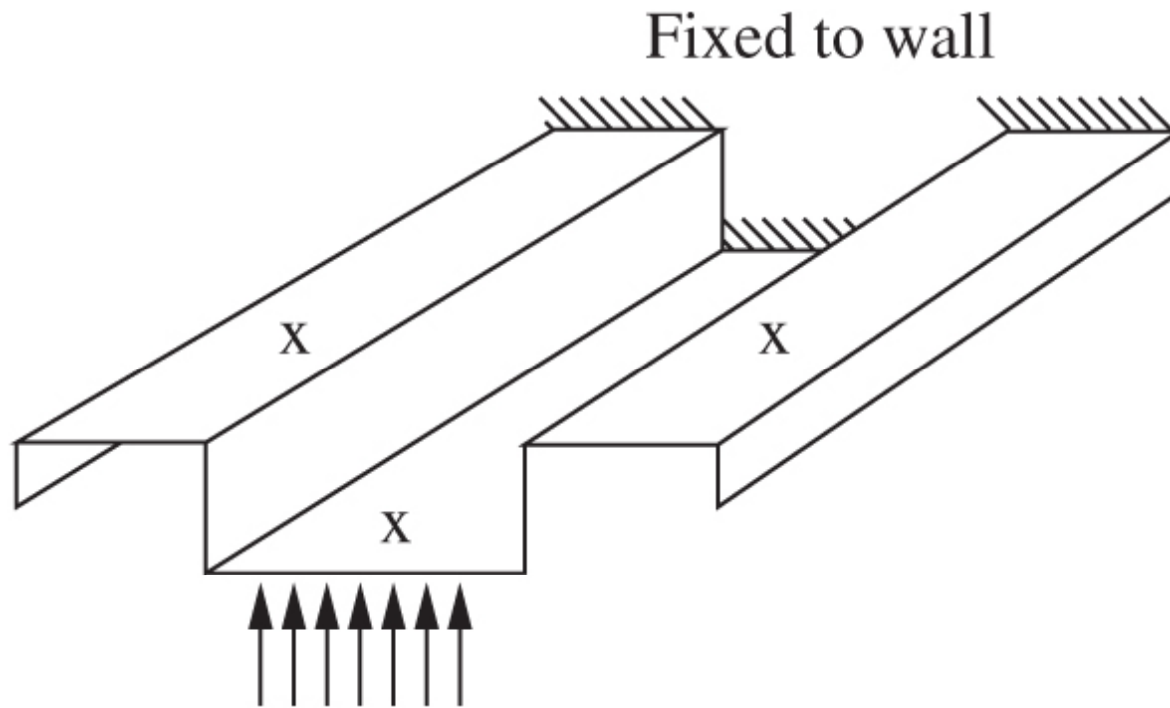
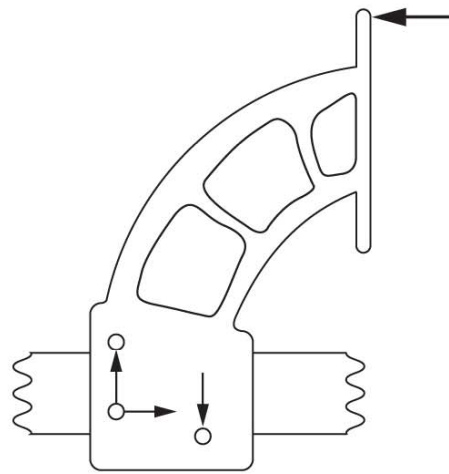

Figure 9.17





(a)



(b)

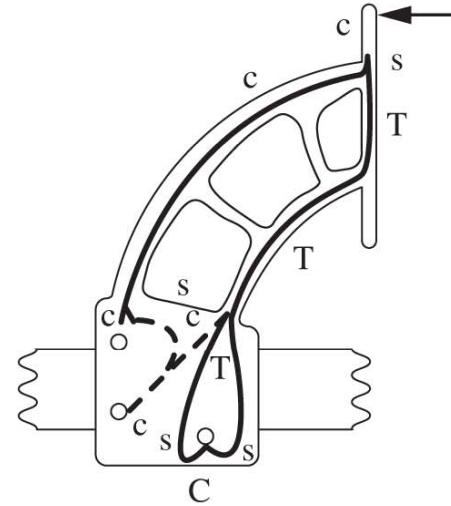

(c)

Irwin Industrial Tools

Figure 9.19

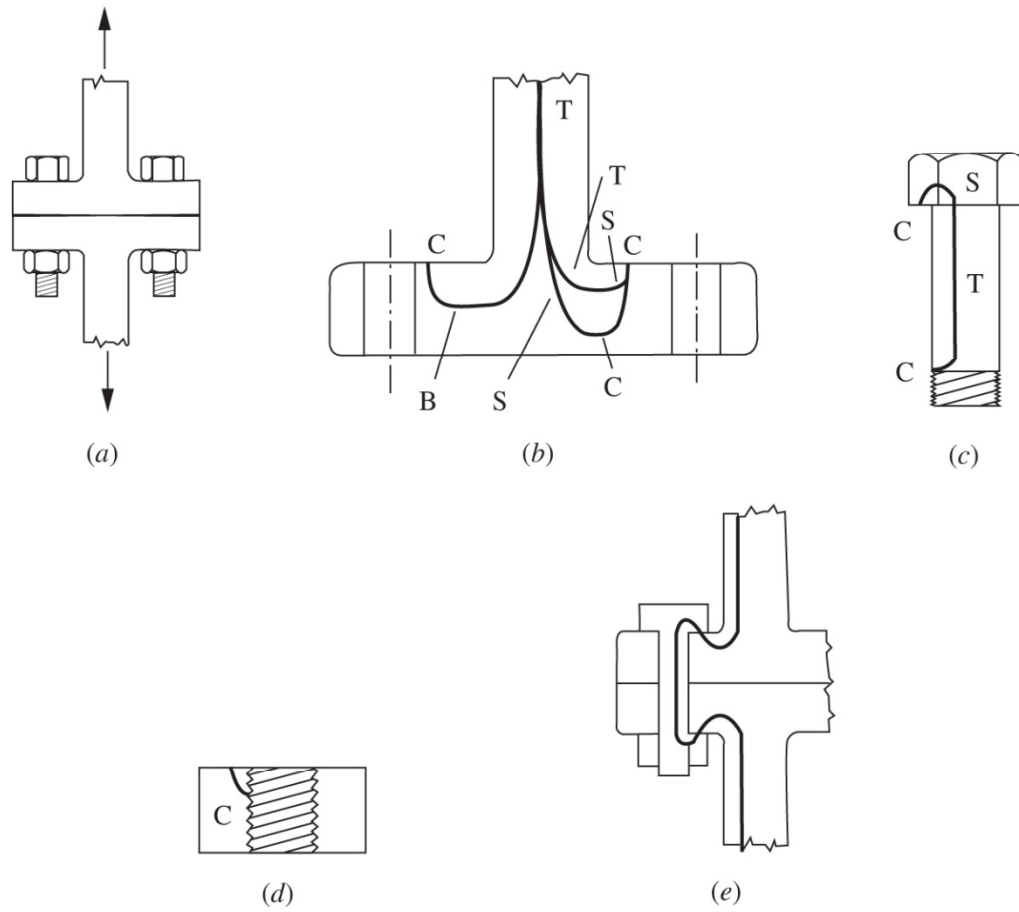
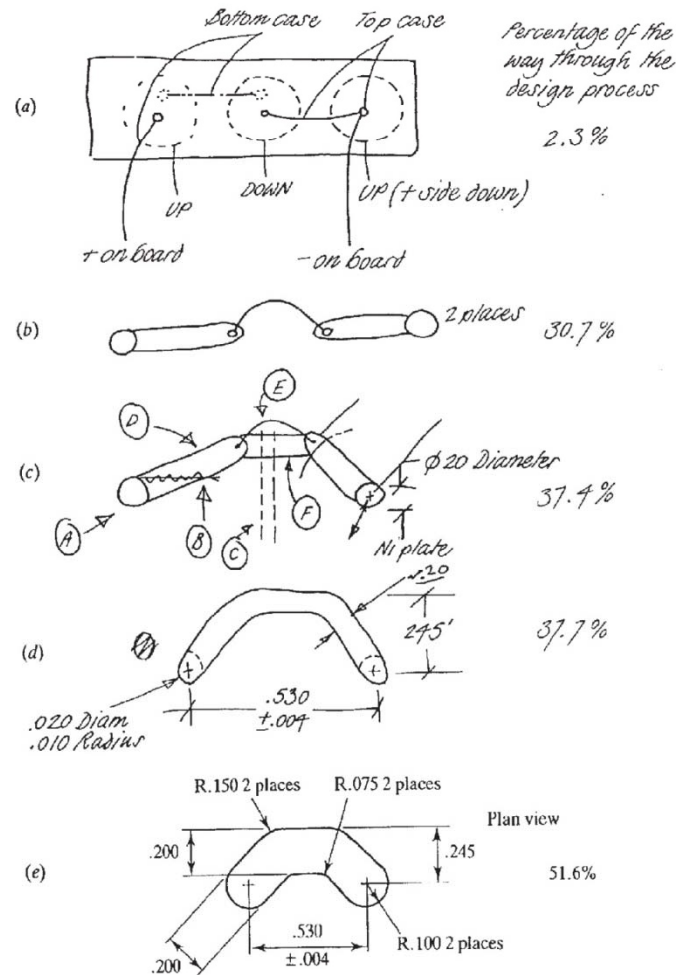



Figure 9.20



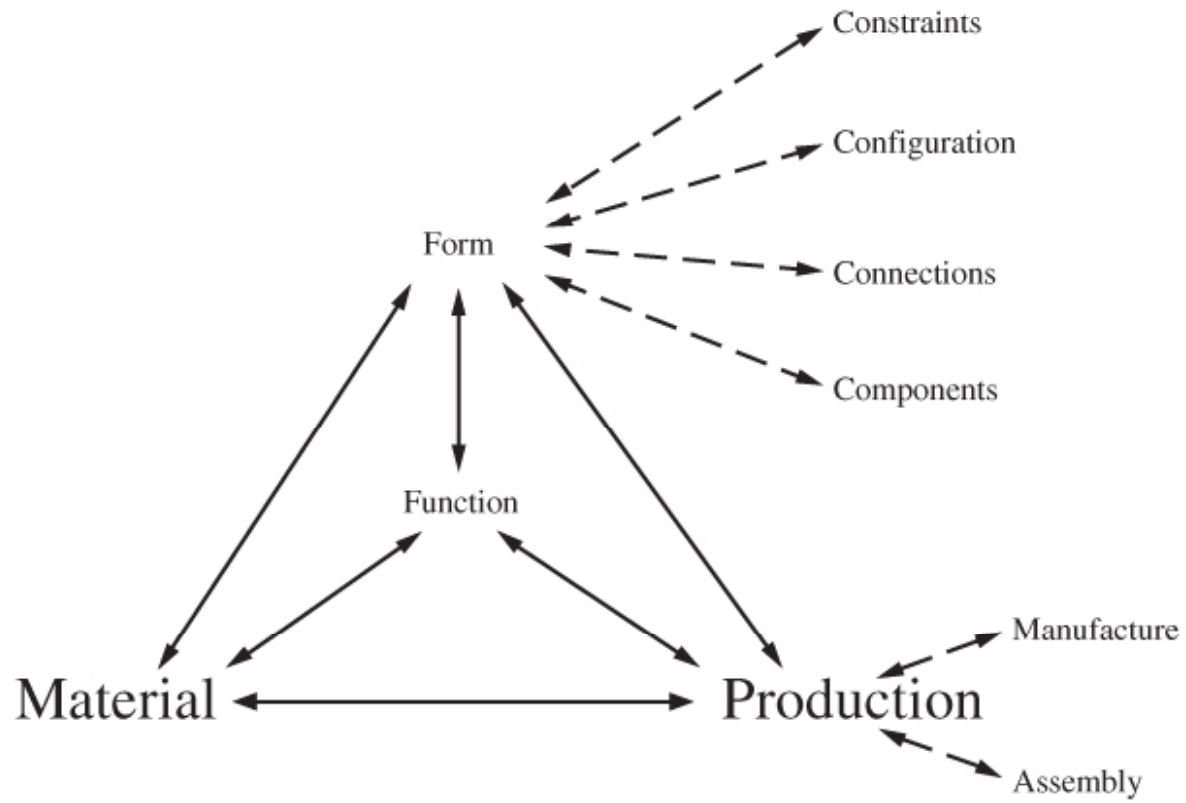

Figure 9.21

Make/Buy or Vendor Selection					
Decision to be made: Make or buy				Date: 09/23/14	
Product: Part 234-4B in Espiral					
Criterion	Wt.	Make	Vendor 1 Allied	Vendor 2 Barns	Vendor 3 Crane
Low development cost	5	2	3	2	4
Low product cost	22	4	2	3	4
High product life cost stability	2	5	3	4	4
Low development lead time	7	3	2	4	2
Low order lead time	11	3	2	5	1
High product quality	14	2	3	3	2
Good product support	6	1	4	2	3
Easy to change product	8	3	5	5	4
Strong IP control	18	4	2	4	2
Good control of order volumes	5	4	1	2	4
Good control of supply chain	2	4	4	2	2
<b>Total</b>		35	31	36	32
<b>Weighted total</b>		3.2	2.56	3.47	2.79
Rationale: Choose Barns as it is significantly better than the others in weighted total and has no great weakness.					
Team member: Bob			Prepared by: Ivin		
Team member: Alvin			Checked by: Becky-Sue		
Team member: Becky-Sue			Approved by: Fredrick		
Team member:					
The Mechanical Design Process			Designed by Professor David G. Ullman		
Copyright 2014, David Ullman			Form # 20.0		

Figure 9.22

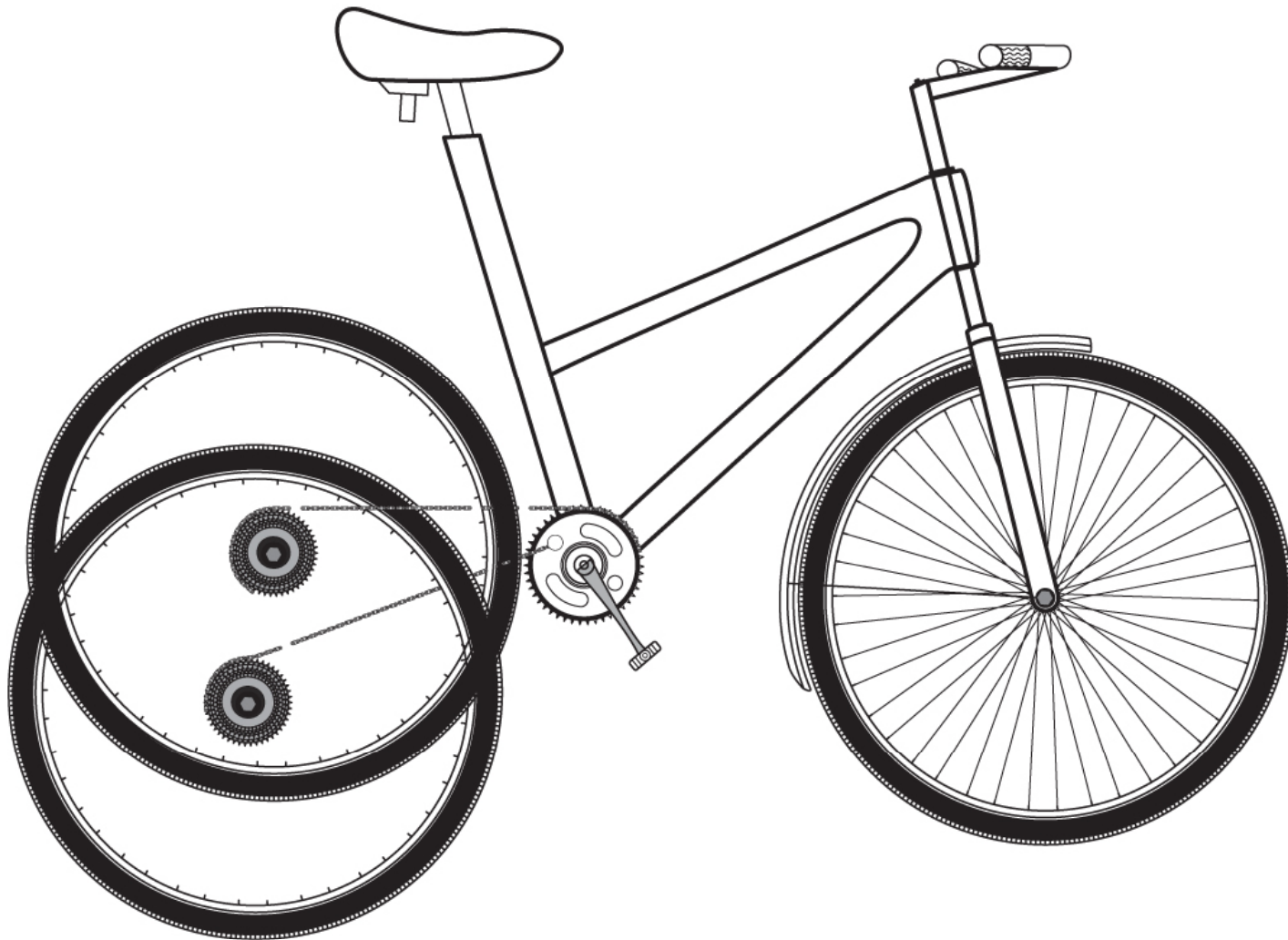
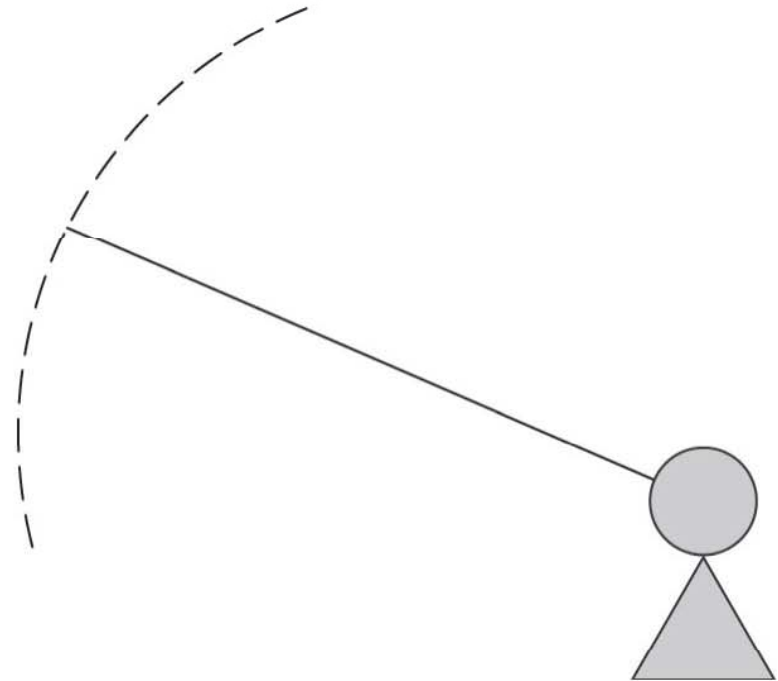

Figure 9.23



Marin Bicycles

Figure 9.24

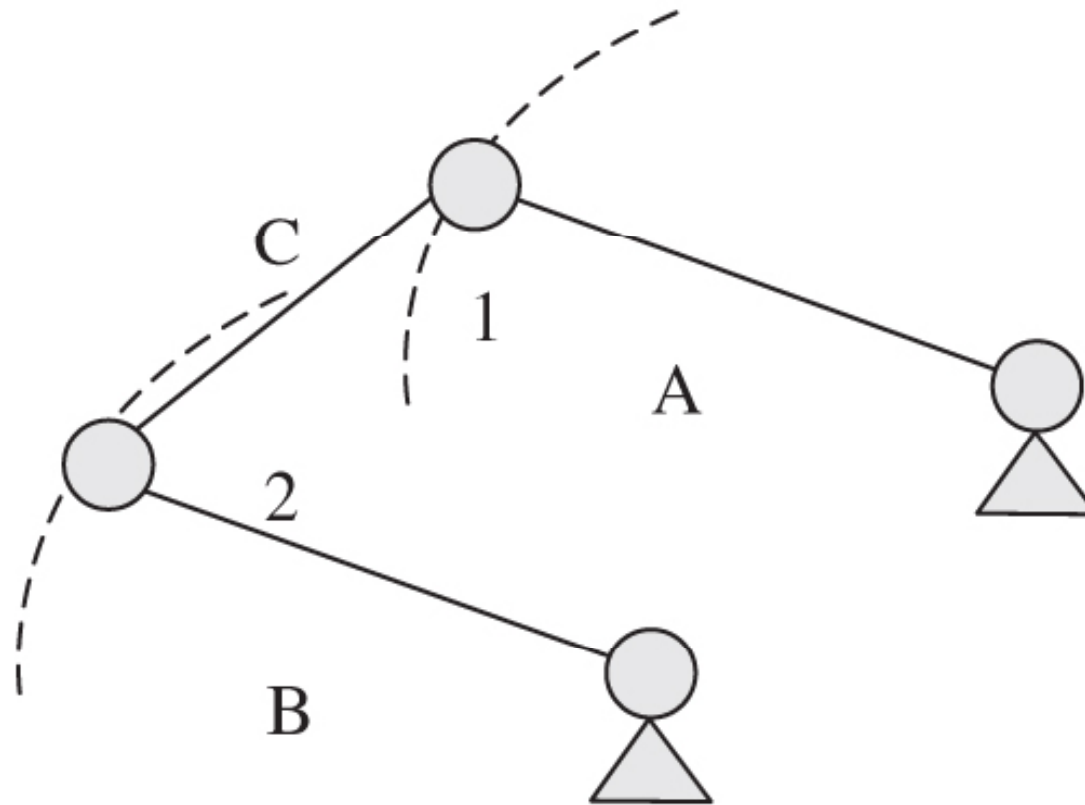

Figure 9.25

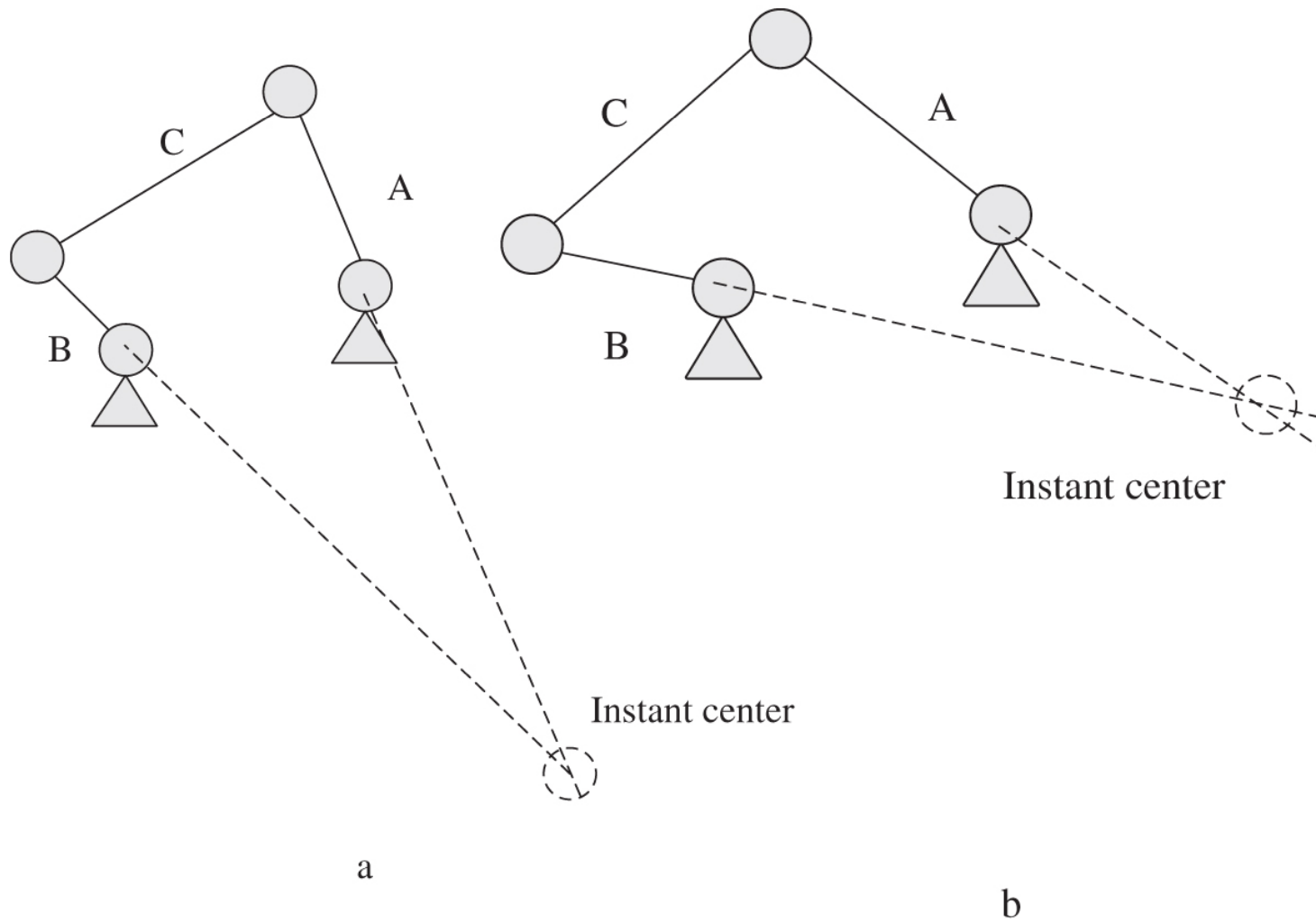

Figure 9.26

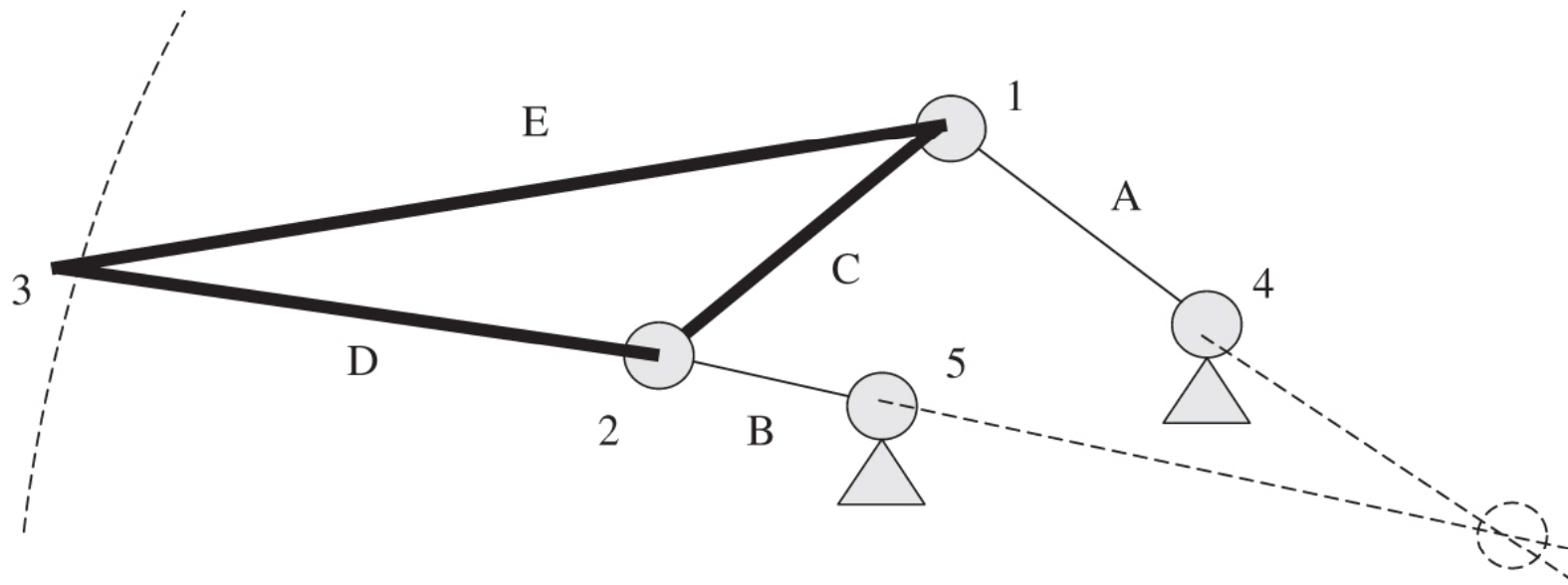
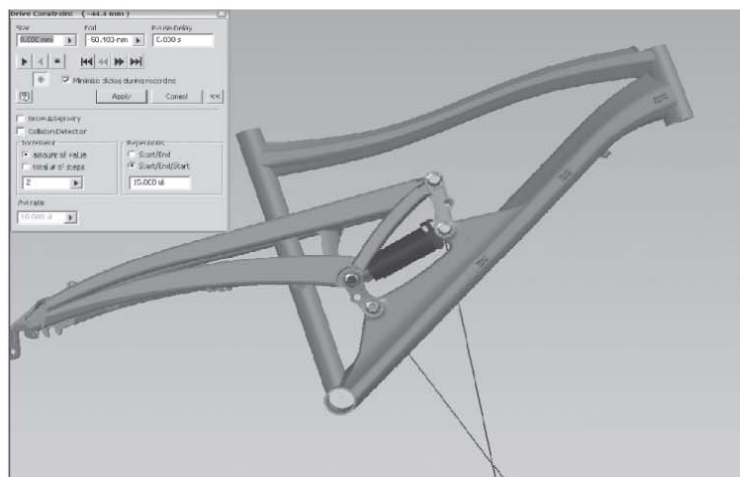
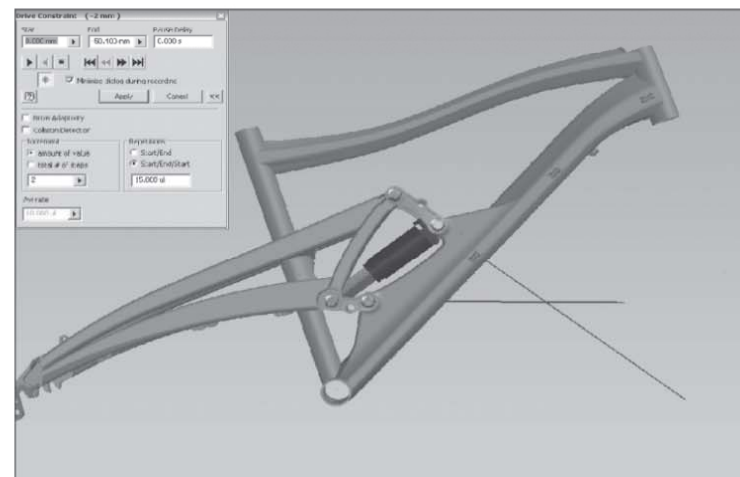



Figure 9.27



(a)



(b)

Figure 9.28

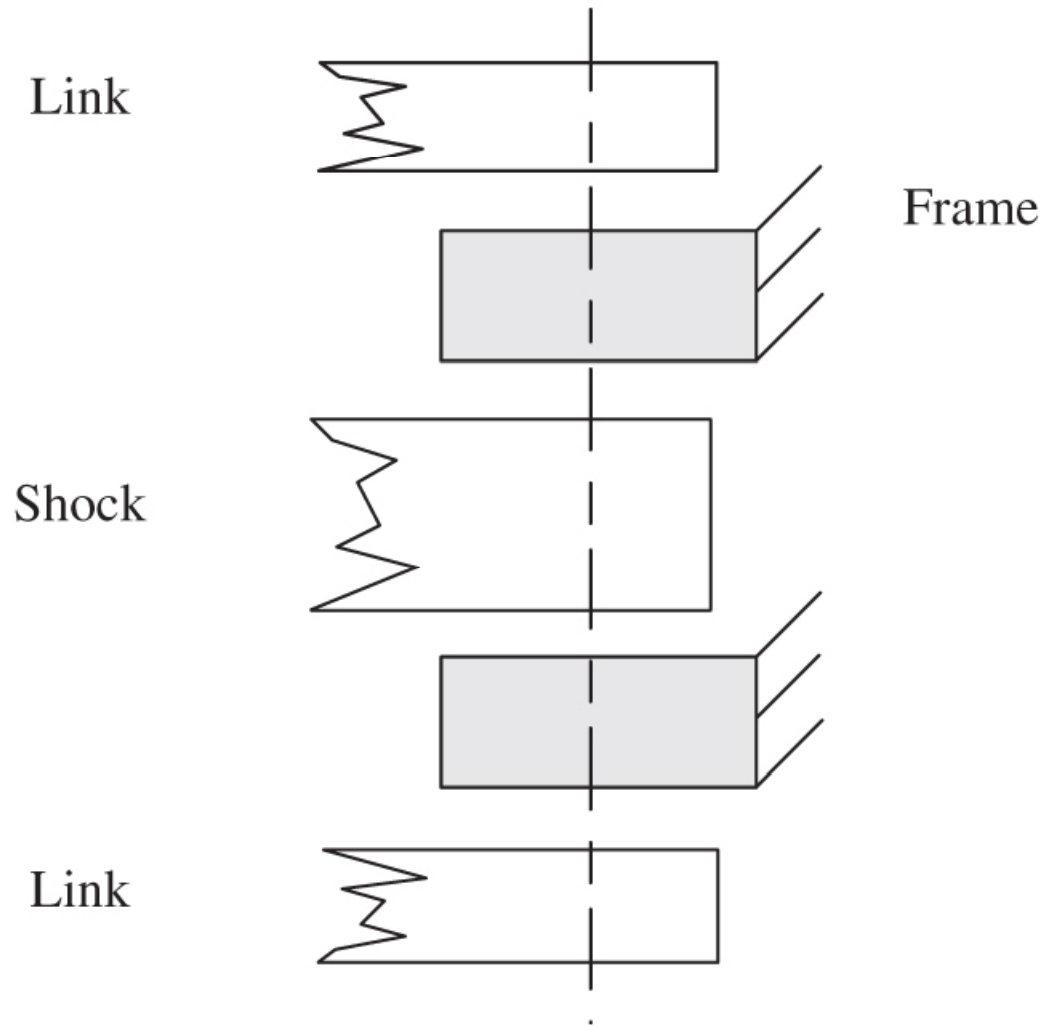
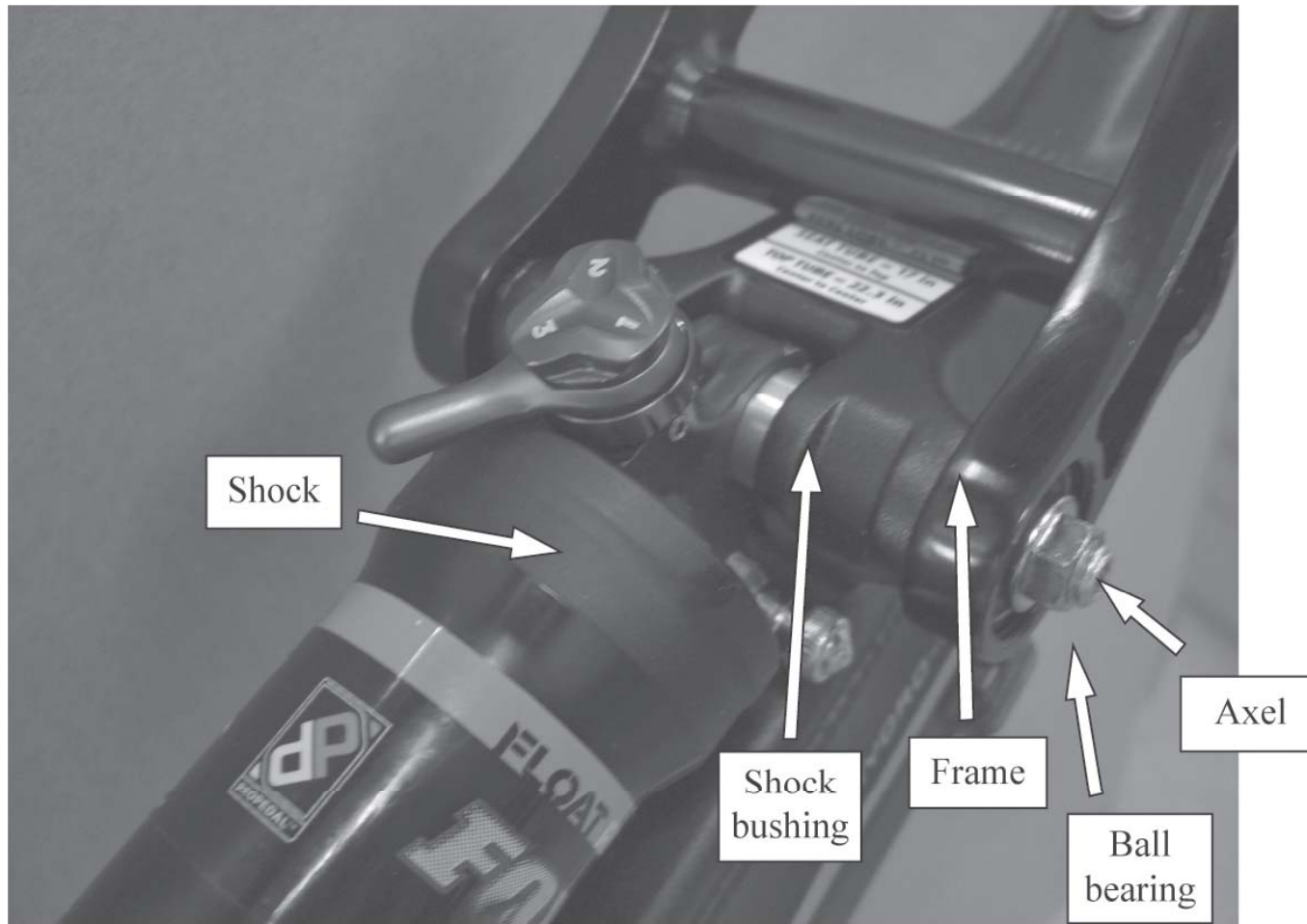

Figure 9.29



David Ullman

Figure 9.30



Marin Bicycles